



SCROLL COMPRESSOR

COMPRESSOR TECHNOLOGY
FOR HVAC & LIGHT COMMERCIAL
APPLICATIONS



GLOBAL NETWORK

Changwon, Korea

· Address 76 Seongsan-dong, Changwon City Gyeongnam,
51554, South Korea
· Phone +82-55-269-3868
· Fax +82-55-268-4896

Tianjin, China

· Address LG Electronics Tianjin appliances Co., Ltd
Xing Dian Rd. Bei Chen Dist., Tianjin, China
· Phone +86-22-2690-3309
+86-22-2690-3542

Rayong, Thailand

· Address LG Electronics(Thailand) Co., Ltd
192 Moo 1, Pluakdaeng Rd.
Tambon Tasith, Ampur Pluakdaeng, Rayong 21140
· Phone +66-038-923-105
+66-038-923-119

Website <https://www.lg.com/global/business/compressor-motor>

Noida, India

· Address LG Electronics India Pvt. Ltd,
Plot No.51, Udyog Vihar,
Surajpur – Kasna Road,
Greater Noida,
Uttar Pradesh, India – 201308
· Phone +91-12-0718-0528
+91-12-0718-0100

Monterrey, Mexico

· Address Av Industrias 180, Kronos, 66603
Cdad. Apodaca, N.L., Mexico
· Phone +52-81-8196-5500

For continual product development, LG reserves the right to change specifications without notice.
© LG Electronics Inc. Printed in Korea. Feb, 2024



Revolutionary energy technologies of the future

LG COMPONENT SOLUTIONS

LG
COMPONENT
SOLUTIONS

COMPRESSOR

MOTOR

Innovation doesn't happen overnight. Ever since we built our very first fan motors in 1962, LG Compressor & Motor has been improving the lives of consumers and businesses alike. For over 60 years, we have been innovating products such as linear compressors, DD motors, scroll compressors, and R1 compressors.

As a business division under LG Electronics, LG Compressor & Motor offers excellent performance and energy efficiency for appliances in refrigeration, air conditioning, and mobility, with sustainable component solutions that meet the latest regulations and standards.

However, we don't just stop there. We have introduced these technologies by manufacturing products built on our decades of technological advancements. That way our customers - manufacturers and product installers - can make a positive difference in the lives of their customers - the end users.

By transitioning to low GWP refrigerants and launching high-efficiency products for our LG Compressor & Motor component solutions, we're able to satisfy more diverse customer needs and pave the way towards an energy future that is more sustainable.

Tailored Solutions Based on a Global Network

Headquartered in South Korea, LG Component Solutions operates production facilities and sales offices in 11 cities and 6 countries around the globe. These various locations fully support our customers in over 50 countries.

LG Component Solutions aims to grow side-by-side with our customers' businesses through ongoing technical consulting for product development, performance and quality optimization for real-world conditions. Those practices, along with a flexible supply chain that enables timely supply, is fueling our commitment to be a trusted partner in the industry.



 **PRODUCTION SITE**

- Korea Changwon
- China Taizhou
- Tianjin
- Nanjing
- Qinhuangdao
- India Noida
- Thailand Rayong
- Mexico Monterrey

 **SALES OFFICE SITE**

- USA Atlanta, Dallas
- India Delhi
- Thailand Rayong
- China Qinhuangdao, Tianjin,
- Taizhou, Shunde
- Korea Seoul, Changwon
- Germany Frankfurt



Technical Support



Real-world Quality



Flexible Supply Chain



Long-term Partnership

Contents

LG Component Solutions	02
Sales Office / Production Site	04



LG Scroll Compressor

Why LG Scroll Compressor	08
Product Platform	09
Product Range	10
Nomenclature	11
Specification	
- Fixed Speed R410A	12
- Fixed Speed R454B	16
- 2 Stage Modulating R410A	18
- 2 Stage Modulating R454B	20
- Variable Speed R410A+R32	22
- For Refrigeration Application	24
- For Heatpump Application	24
Drawing	26
Specification	
- Residential Inverter Drive	30
- Commercial Inverter Drive	31
Wiring Diagram / Mounting	32
Accessory Parts / Packing & Container Stuffing Quantity	33



Why LG Scroll Compressor?

LG offers an extensive selection of scroll compressors for fixed speed, two-stage modulating, and variable speed with an optimized inverter driver to fully support various applications.



Fixed Speed Compressor -The next generation

With a focus on reliability and performance, LG designed Gen 3 scroll compressors with significant improvements to motor efficiency and friction reduction to bring the future to the present.

2-Stage Modulating

LG 2-stage modulating compressors are built under precise quality standards and exacting durability requirements for the global marketplace. By operating at 2 capacities, the LG 2-stage scroll compressor can function in savings mode in moderate environments and in power mode in high demand situations. By modulating between 2 stages, it runs longer and more efficiently than its single stage counterpart.

R1 Compressor™

Featuring a groundbreaking design that combines the technology of a conventional scroll and rotary compressor, the R1 compressor™ delivers enhanced heating performance. With the motor positioned at the top of the unit and the scroll at the center, the R1's simplified structure leads to significant efficiency improvement and sound reduction.



Product Platform

Fixed Speed				
Model				
	Gen2	Gen3	Commercial	Refrigeration
Capacity Range	1.5 - 5 Ton	1.5 - 5 Ton	6 - 10 Ton	1.5 - 5 Ton
Application	14+ SEER Air Conditioning and Heatpump	15+ SEER Air Conditioning and Heatpump	Commercial Air Conditioning & Heatpump	Medium temperature Low temperature
Feature	<ul style="list-style-type: none"> - Internal bypass valve system - Improve scroll and seal design - Apply reliable oil 	<ul style="list-style-type: none"> - Improved suction path smooth re-start Low GWP refrigerant 	<ul style="list-style-type: none"> - Internal bypass valve system - Apply reliable oil 	<ul style="list-style-type: none"> - Internal bypass valve system - Optimized deep vacuum protector - Apply reliable oil

Modulation		Variable Speed	
Model			
	Two-Stage	R1™	High Side Shell
Capacity Range	1.5 - 5 Ton	2 - 5 Ton	1 - 21 Ton
Application	15-16 SEER Air Conditioning and Heatpump (including commercial)	28+ SEER Air Conditioning and Heatpump	VRF system
Feature	<ul style="list-style-type: none"> - Internal bypass valve system - Improved part-load and full load performance - Apply reliable oil 	<ul style="list-style-type: none"> - Internal bypass valve system - Apply reliable oil 	<ul style="list-style-type: none"> - Internal bypass valve system - Optimized deep vacuum protector - Apply reliable oil



Product Range

Fixed Speed / HVAC

Capacity [RT, Tonnage] (1 RT = 12 kBtu/hr=3.5 kW)		Series	1.5	2.0	2.5	3.0	3.5	4.0	4.5	5.0	5.5	6.0	6.5	7.0	7.5	8.0
R410A	ARA											●	●	●	●	●
	APG		●	●	●	●										
	ABG						●	●	●	●	●	●				
	ABT						●	●	●	●	●	●	●			
	APH		●	●	●	●	●									
	ABH							●	●	●	●					
R454B	YPH		●	●	●	●										
	YBH							●	●	●						

Fixed Speed / Refrigeration

Capacity [RT, Tonnage] (1 RT = 12 kBtu/hr=3.5 kW)		Series	1.5	2.0	2.5	3.0	3.5	4.0	4.5	5.0	5.5	6.0	6.5	7.0	7.5	8.0
R404A	MPA		●	●	●											
	MBA						●	●	●	●						
	MRA										●	●	●			

Two-Stage Modulating

Capacity [RT, Tonnage] (1 RT = 12 kBtu/hr=3.5 kW)		Series	1.5	2.0	2.5	3.0	3.5	4.0	4.5	5.0	5.5	6.0	6.5	7.0	7.5	8.0
R410A	APM		●	●	●	●										
	ABM						●	●	●	●						
R454B	YPM		●	●	●	●										
	YBM						●	●	●	●						

Variable Speed / High Side Shell

Capacity [RT, Tonnage] (1 RT = 12 kBtu/hr=3.5 kW)		Series	1.0	2.0	3.0	4.0	5.0	6.0	7.0	8.0	9.0	10.0	20.0
R410A	JQC						●				●		
	JBA												●
R32	JQC										●		

Variable Speed / R1 Compressor™

Capacity [RT, Tonnage] (1 RT = 12 kBtu/hr=3.5 kW)		Series	0.5	1.0	1.5	2.0	2.5	3.0	3.5	4.0	4.5	5.0	5.5	6.0	6.5	7.0	7.5	8.0	8.5	9.0
R410A	RJ				●							●								
R32	RJ							●												



Nomenclature

Y P H 029 K A A

Refrigerant

Code	Refrigerant	Type
A	R410A	LSS
J	R410A	HSS
M	MULTI*	LSS
S	R22	LSS
T	R32	LSS
Y	R454B	LSS

*R404A, R507, R407A, R407C, R448A, R449A

Compressor size (mm)

P : Φ139 R : Φ179
Q : Φ147 G : Φ224
B : Φ160

Generation code

(A-Z)

Capacity

(Btu/Hr x 1,000) @ 60 Hz

Exterior specification
(A-Z)

Motor specification
(A-Z)

Motor code

Code	Power source			Motor
	Phase(Φ)	Voltage	Hz	
K	1	208 - 230	60	Fixed Speed
P	1	220 - 240	50	Fixed Speed
R	3	208 - 230	60	Fixed Speed
S	3	460	60	Fixed Speed
T	3	575	60	Fixed Speed
U	3	380	60	Fixed Speed
W	3	460	60	Fixed Speed
		380 - 420	50	Fixed Speed
Y	3	380 - 420	50	Fixed Speed
D	Inverter			Variable Speed
M				
Q	1	265	60	Fixed Speed

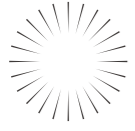

Specification

Fixed Speed R410A [1 of 2]

Type	Frequency	Voltage	Series	Model	Cooling Capacity		Input Watts	EER Btu/W·hr	COP W/W	Test Condition (Cond / Eva Temp) °C
					Btu/hr	Watts				
LSS	50 Hz	1φ, 220/240V	ABT	ABT034PT	28,000	8,201	2,888	9.70	2.84	54.4 / 7.2
				ABT042YT	34,900	10,228	3,421	10.20	2.99	54.4 / 7.2
		3φ, 380 / 420 V	ABT	ABT048YT	40,200	11,781	3,688	10.90	3.19	54.4 / 7.2
				ABT049YM	40,800	11,949	3,760	10.85	3.18	54.4 / 7.2
				ABT051YT	42,500	12,447	3,900	10.90	3.19	54.4 / 7.2
				ABT054YT	44,800	13,121	4,150	10.80	3.16	54.4 / 7.2
				ABT054YM	44,400	13,013	4,160	10.67	3.13	54.4 / 7.2
				ABT057YT	48,500	14,204	4,450	10.90	3.19	54.4 / 7.2
				ABT061YT	51,500	15,083	4,725	10.90	3.19	54.4 / 7.2
				ABT061YM	50,500	14,801	4,720	10.70	3.14	54.4 / 7.2
		1φ, 208 - 230 V	ARA	ARA061KA	64,000	18,756	6,038	10.60	3.11	54.4 / 7.2
				ARA072KA	72,000	21,101	6,857	10.50	3.08	54.4 / 7.2
				ARA083KA	83,000	24,324	7,905	10.50	3.08	54.4 / 7.2
		1φ, 208 - 230 V	ABT	ABT038KT	38,700	11,342	3,650	10.60	3.11	54.4 / 7.2
	ABT042KT			42,200	12,359	3,980	10.60	3.11	54.4 / 7.2	
	ABT048KT			48,000	14,058	4,444	10.80	3.16	54.4 / 7.2	
	ABT051KT			51,200	14,058	4,740	10.80	2.97	54.4 / 7.2	
	ABT054KA			54,000	15,815	4,820	11.20	3.28	54.4 / 7.2	
	ABT057KM			57,100	16,735	6,000	9.52	2.79	54.4 / 7.2	
	3φ, 208 - 230 V	ABT	ABT054RM	54,200	15,885	5,160	10.50	3.08	54.4 / 7.2	
			ABT061RM	61,600	18,054	5,860	10.51	3.08	54.4 / 7.2	
	3φ, 380 V	ABT	ABT054UM	53,500	15,669	4,953	10.80	3.16	54.4 / 7.2	
	60 Hz	1φ, 208 - 230 V	APG	APG016KA	19,300	5,656	1,290	14.96	4.38	46.1 / 10.0
				APG016KB	19,300	5,656	1,250	15.44	4.52	46.1 / 10.0
				APG020KA	24,800	7,268	1,570	15.80	4.63	46.1 / 10.0
				APG020KB	24,800	7,268	1,570	15.80	4.63	46.1 / 10.0
				APG024KA	29,500	8,646	1,870	15.78	4.62	46.1 / 10.0
				APG024KB	29,600	8,675	1,860	15.91	4.66	46.1 / 10.0
				APG025KA	31,400	9,202	1,960	16.02	4.69	46.1 / 10.0
				APG029KA	35,800	10,492	2,200	16.27	4.77	46.1 / 10.0
				APG031KA	38,500	11,283	2,360	16.31	4.78	46.1 / 10.0
				1φ, 208 - 230 V	ABG	ABG034KA	42,500	12,449	2,707	15.70
		ABG034KB	42,500			12,449	2,700	15.74	4.61	46.1 / 10.0
		ABG036KA	44,700			13,093	2,790	16.02	4.69	46.1 / 10.0
		ABG036KB	44,700			13,093	2,790	16.02	4.69	46.1 / 10.0
		ABG038KA	46,800			13,708	2,890	16.19	4.74	46.1 / 10.0
		ABG039KA	48,200			14,118	3,000	16.07	4.71	46.1 / 10.0
		ABG039KB	48,200			14,118	3,000	16.07	4.71	46.1 / 10.0
		ABG042KA	52,000			15,231	3,200	16.25	4.76	46.1 / 10.0
		ABG049KA	61,000			17,868	3,730	16.35	4.79	46.1 / 10.0
		ABG051KA	63,000			18,453	3,830	16.45	4.82	46.1 / 10.0
		1φ, 265 V	APG			APG021QA	26,300	7,706	1,680	15.65

*LSS : Low Side Shell

Cooling Capacity	Input	EER	COP	Test Condition (Cond / Eva Temp) °C	Dimension (mm)			
					A	B	C	
					444	421	315	
					406	382	276	
					444	421	315	
					444	421	315	
					444	421	315	
					444	421	315	
					444	421	315	
					444	421	315	
					444	421	315	
86,000	25,204	4,300	20.00	5.86	37.8 / 10.0	466	437	325
					466	437	325	
					466	437	325	
					444	421	315	
					444	421	315	
					444	421	315	
					444	421	315	
					444	421	315	
					444	421	315	
					444	421	315	
					444	421	315	
					444	421	315	
					444	421	315	
21,300	6,242	1,040	20.48	6.00	37.8 / 10.0	385	363	263
21,400	6,272	1,019	21.00	6.16	37.8 / 10.0	385	363	263
27,300	8,001	1,294	21.10	6.18	37.8 / 10.0	385	363	263
27,300	8,001	1,264	21.60	6.33	37.8 / 10.0	385	363	263
32,700	9,583	1,520	21.51	6.30	37.8 / 10.0	385	363	263
32,900	9,642	1,516	21.70	6.36	37.8 / 10.0	385	363	263
35,000	10,257	1,606	21.79	6.39	37.8 / 10.0	385	363	263
39,600	11,606	1,808	21.90	6.42	37.8 / 10.0	385	363	263
42,800	12,543	1,937	22.10	6.48	37.8 / 10.0	385	363	263
47,150	13,809	2,214	21.30	6.24	37.8 / 10.0	419	394	295
47,150	13,809	2,214	21.30	6.24	37.8 / 10.0	419	394	295
49,400	14,468	2,298	21.50	6.30	37.8 / 10.0	419	394	295
49,400	14,468	2,298	21.50	6.30	37.8 / 10.0	419	394	295
51,400	15,054	2,369	21.70	6.35	37.8 / 10.0	419	394	295
53,000	15,522	2,477	21.40	6.27	37.8 / 10.0	419	394	295
53,000	15,522	2,477	21.40	6.27	37.8 / 10.0	419	394	295
57,100	16,723	2,631	21.70	6.36	37.8 / 10.0	419	394	295
67,300	19,710	3,087	21.80	6.38	37.8 / 10.0	419	394	295
69,500	20,355	3,188	21.80	6.38	37.8 / 10.0	419	394	295
29,100	8,526	1,370	21.24	6.22	37.8 / 10.0	385	363	263



Specification

Fixed Speed R410A [2 of 2]

Type	Frequency	Voltage	Series	Model	Cooling Capacity		Input	EER	COP	Test Condition (Cond / Eva Temp)	
					Btu/hr	Watts	Watts	Btu/W-hr	W/W	°C	
LSS	60 Hz	3φ, 208 - 230 V	APG	APG029RA	35,200	10,316	2,220	15.86	4.65	46.1 / 10.0	
				APG031RA	37,800	11,078	2,400	15.75	4.62	46.1 / 10.0	
			ABG	ABG036RA	44,400	13,005	2,790	15.91	4.66	46.1 / 10.0	
				ABG038RA	47,000	13,767	2,920	16.10	4.71	46.1 / 10.0	
				ABG039RA	48,400	14,177	3,000	16.13	4.73	46.1 / 10.0	
				ABG042RA	51,700	15,144	3,210	16.11	4.72	46.1 / 10.0	
				ABG049RA	61,200	17,926	3,760	16.28	4.77	46.1 / 10.0	
				ABG051RA	63,100	18,483	3,870	16.30	4.78	46.1 / 10.0	
			ABG054RA	66,900	19,596	4,120	16.24	4.76	46.1 / 10.0		
				APG029TA	35,200	10,316	2,210	15.93	4.67	46.1 / 10.0	
				APG031TA	37,700	11,049	2,380	15.84	4.64	46.1 / 10.0	
				ABG	ABG039TA	48,400	14,177	3,000	16.13	4.73	46.1 / 10.0
		ABG042TA			51,700	15,144	3,210	16.11	4.72	46.1 / 10.0	
		ABG049TA		61,200	17,926	3,770	16.23	4.75	46.1 / 10.0		
		ABG051TA	63,000	18,453	3,890	16.20	4.74	46.1 / 10.0			
		ABG054TA	66,900	19,596	4,150	16.12	4.72	46.1 / 10.0			
		50 / 60 Hz	3φ, 380 / 420 V, 50 Hz	APG	APG029WA	28,600	8,382	1,860	15.38	4.51	46.1 / 10.0
					APG029WA	35,200	10,316	2,220	15.86	4.65	46.1 / 10.0
					APG031WA	30,700	8,998	1,990	15.43	4.52	46.1 / 10.0
				ABG	APG031WA	37,600	11,019	2,370	15.86	4.65	46.1 / 10.0
					ABG039WA	40,200	11,775	2,510	16.02	4.69	46.1 / 10.0
					ABG039WA	48,400	14,177	3,000	16.13	4.73	46.1 / 10.0
					ABG042WA	42,900	12,566	2,670	16.07	4.71	46.1 / 10.0
					ABG042WA	51,700	15,144	3,210	16.11	4.72	46.1 / 10.0
	ABG049WA				50,300	14,733	3,170	15.87	4.65	46.1 / 10.0	
	ABG049WA				61,100	17,897	3,760	16.25	4.76	46.1 / 10.0	
	ABG051WA				52,000	15,231	3,260	15.95	4.67	46.1 / 10.0	
	ABG051WA				63,000	18,453	3,860	16.32	4.78	46.1 / 10.0	
	ABG054WA		55,200	16,169	3,430	16.09	4.71	46.1 / 10.0			
	ABG054WA		66,900	19,596	4,120	16.24	4.76	46.1 / 10.0			
	3φ, 460 V, 60 Hz		APG	APH014KA	18,300	5,362	1,160	15.78	4.62	46.1 / 10.0	
				APH020KA	24,900	7,296	1,513	16.46	4.82	46.1 / 10.0	
				APH021KA	26,500	7,765	1,615	16.41	4.81	46.1 / 10.0	
				APH024KA	29,700	8,702	1,790	16.59	4.86	46.1 / 10.0	
				APH025KA	31,500	9,230	1,895	16.62	4.87	46.1 / 10.0	
				APH029KA	36,000	10,548	2,185	16.48	4.83	46.1 / 10.0	
			ABH	APH031KA	39,000	11,427	2,318	16.82	4.93	46.1 / 10.0	
				APH034KA	43,000	12,599	2,595	16.57	4.86	46.1 / 10.0	
				APH036KA	44,400	13,009	2,670	16.63	4.87	46.1 / 10.0	
				ABH039KA	48,500	14,211	2,920	16.61	4.87	46.1 / 10.0	
		ABH042KA		52,100	15,265	3,120	16.70	4.89	46.1 / 10.0		
		ABH049KA		61,300	17,961	3,670	16.70	4.89	46.1 / 10.0		
	APG	ABH051KA	63,600	18,635	3,800	16.74	4.90	46.1 / 10.0			
		APH025RA	31,100	9,112	1,981	15.70	4.60	46.1 / 10.0			
	ABH	ABH051RA	63,600	18,635	3,800	16.74	4.90	46.1 / 10.0			
		50 / 60 Hz	3φ, 380 / 420 V, 50 Hz	ABH	ABH051WA	51,900	15,207	3,250	15.97	4.68	46.1 / 10.0
	ABH051WA				63,600	18,635	3,800	16.74	4.90	46.1 / 10.0	

*LSS : Low Side Shell

Cooling Capacity		Input	EER	COP	Test Condition (Cond / Eva Temp)	Dimension (mm)		
Btu/hr	Watts	Watts	Btu/W-hr	W/W	°C	A	B	C
39,000	11,430	1,822	21.41	6.27	37.8 / 10.0	385	363	263
41,700	12,221	1,949	21.40	6.27	37.8 / 10.0	385	363	263
49,400	14,477	2,298	21.50	6.30	37.8 / 10.0	419	394	295
51,600	15,112	2,370	21.77	6.38	37.8 / 10.0	419	394	295
53,000	15,532	2,431	21.80	6.39	37.8 / 10.0	419	394	295
57,100	16,723	2,631	21.70	6.36	37.8 / 10.0	419	394	295
67,400	19,740	3,092	21.80	6.38	37.8 / 10.0	419	394	295
69,500	20,355	3,188	21.80	6.38	37.8 / 10.0	419	394	295
74,500	21,833	3,304	22.55	6.61	37.8 / 10.0	419	394	295
39,000	11,430	1,806	21.59	6.33	37.8 / 10.0	385	363	263
41,700	12,221	1,926	21.65	6.35	37.8 / 10.0	385	363	263
53,000	15,532	2,431	21.80	6.39	37.8 / 10.0	419	394	295
57,100	16,723	2,619	21.80	6.39	37.8 / 10.0	419	394	295
67,400	19,740	3,092	21.80	6.38	37.8 / 10.0	419	394	295
69,500	20,355	3,188	21.80	6.38	37.8 / 10.0	419	394	295
74,000	21,700	3,410	21.70	6.36	37.8 / 10.0	419	394	295
32,000	9,378	1,488	21.51	6.30	37.8 / 10.0	385	363	263
39,100	11,459	1,802	21.70	6.36	37.8 / 10.0	385	363	263
34,400	10,082	1,585	21.70	6.36	37.8 / 10.0	385	363	263
41,600	12,192	1,917	21.70	6.36	37.8 / 10.0	385	363	263
43,600	12,767	2,000	21.80	6.38	37.8 / 10.0	419	394	295
53,000	15,532	2,431	21.80	6.39	37.8 / 10.0	419	394	295
47,600	13,941	2,183	21.80	6.39	37.8 / 10.0	419	394	295
57,100	16,723	2,619	21.80	6.39	37.8 / 10.0	419	394	295
55,800	16,342	2,560	21.80	6.38	37.8 / 10.0	419	394	295
67,400	19,736	3,092	21.80	6.38	37.8 / 10.0	419	394	295
57,700	16,899	2,647	21.80	6.38	37.8 / 10.0	419	394	295
69,500	20,355	3,188	21.80	6.38	37.8 / 10.0	419	394	295
61,000	17,862	2,824	21.60	6.33	37.8 / 10.0	419	394	295
74,000	21,669	3,410	21.70	6.35	37.8 / 10.0	419	394	295
20,000	5,860	919	21.76	6.38	37.8 / 10.0	385	363	263
27,400	8,028	1,220	22.46	6.58	37.8 / 10.0	385	363	263
29,400	8,614	1,309	22.46	6.58	37.8 / 10.0	385	363	263
32,700	9,581	1,443	22.66	6.64	37.8 / 10.0	385	363	263
34,900	10,226	1,534	22.75	6.67	37.8 / 10.0	385	363	263
39,600	11,603	1,747	22.67	6.64	37.8 / 10.0	385	363	263
42,500	12,453	1,867	22.76	6.67	37.8 / 10.0	385	363	263
47,300	13,859	2,134	22.16	6.49	37.8 / 10.0	385	363	263
49,300	14,445	2,204	22.37	6.55	37.8 / 10.0	385	363	263
53,200	15,588	2,356	22.58	6.62	37.8 / 10.0	419	394	295
57,600	16,877	2,542	22.66	6.64	37.8 / 10.0	419	394	295
67,500	19,778	2,978	22.67	6.64	37.8 / 10.0	419	394	295
69,800	20,451	3,080	22.66	6.64	37.8 / 10.0	419	394	295
34,300	10,050	1,981	17.31	5.07	37.8 / 10.0	385	363	263
69,800	20,451	3,080	22.66	6.64	37.8 / 10.0	419	394	295
57,600	16,877	2,600	22.15	6.49	37.8 / 10.0	419	394	295
69,800	20,451	3,080	22.66	6.64	37.8 / 10.0	419	394	295



Specification

Fixed Speed R454B

Type	Frequency	Voltage	Series	Model	Cooling Capacity (DOE A)		Input	EER	COP	Test Condition (Cond / Eva Temp)			
					Btu/hr	Watts	Watts	Btu/W-hr	W/W	°C			
LSS	60 Hz	1φ, 208 - 230 V	YPH	YPH014KA	18,350	5,377	1,135	16.17	4.74	46.1 / 10.0			
				YPH016KA	19,500	5,714	1,192	16.36	4.79	46.1 / 10.0			
				YPH020KA	24,800	7,266	1,498	16.56	4.85	46.1 / 10.0			
				YPH021KA	26,600	7,794	1,597	16.66	4.88	46.1 / 10.0			
				YPH024KA	29,700	8,702	1,772	16.76	4.91	46.1 / 10.0			
				YPH025KA	31,300	9,171	1,890	16.56	4.85	46.1 / 10.0			
				YPH029KA	36,000	10,548	2,134	16.87	4.94	46.1 / 10.0			
				YPH031KA	38,600	11,310	2,280	16.93	4.96	46.1 / 10.0			
				YPH034KA	42,600	12,482	2,573	16.56	4.85	46.1 / 10.0			
				YPH036KA	44,700	13,097	2,684	16.65	4.88	46.1 / 10.0			
	60 Hz	3φ, 208 - 230 V	YBH	YBH039KA	48,500	14,211	2,877	16.86	4.94	46.1 / 10.0			
				YBH042KA	52,200	15,295	3,115	16.76	4.91	46.1 / 10.0			
				YBH049KA	61,400	17,990	3,664	16.76	4.91	46.1 / 10.0			
				YBH051KA	63,300	18,547	3,777	16.76	4.91	46.1 / 10.0			
				YPH	YPH031RA	38,300	11,222	2,238	17.11	5.01	46.1 / 10.0		
					YPH036RA	44,500	13,039	2,670	16.67	4.88	46.1 / 10.0		
				YBH	YBH042RA	52,200	15,295	3,097	16.86	4.94	46.1 / 10.0		
					YBH051RA	63,000	18,459	3,740	16.84	4.94	46.1 / 10.0		
				50 / 60 Hz	3φ, 380 / 420 V, 50 Hz	YPH	YPH031WA	31,000	9,083	1,860	16.67	4.88	46.1 / 10.0
							YPH031WA	38,400	11,251	2,238	17.16	5.03	46.1 / 10.0
YBH	YBH042WA	43,000	12,599			2,540	16.93	4.96	46.1 / 10.0				
	YBH042WA	52,200	15,295			3,088	16.90	4.95	46.1 / 10.0				
	YBH051WA	52,200	15,295			3,150	16.57	4.86	46.1 / 10.0				
	YBH051WA	63,300	18,547			3,720	17.02	4.99	46.1 / 10.0				

*LSS : Low Side Shell

Cooling Capacity (DOE B)		Input	EER	COP	Test Condition (Cond / Eva Temp)	Dimension (mm)		
Btu/hr	Watts	Watts	Btu/W-hr	W/W	°C	A	B	C
20,200	5,919	914	22.10	6.48	37.8 / 10.0	385	363	263
21,200	6,211	957	22.15	6.49	37.8 / 10.0	385	363	263
27,300	7,999	1,210	22.56	6.61	37.8 / 10.0	385	363	263
29,350	8,600	1,290	22.75	6.67	37.8 / 10.0	385	363	263
32,000	9,376	1,419	22.55	6.61	37.8 / 10.0	385	363	263
34,400	10,080	1,525	22.56	6.61	37.8 / 10.0	385	363	263
39,400	11,544	1,731	22.76	6.67	37.8 / 10.0	385	363	263
41,700	12,218	1,835	22.72	6.66	37.8 / 10.0	385	363	263
46,700	13,683	2,089	22.36	6.55	37.8 / 10.0	385	363	263
48,600	14,240	2,194	22.15	6.49	37.8 / 10.0	385	363	263
52,200	15,295	2,314	22.56	6.61	37.8 / 10.0	419	394	295
56,800	16,642	2,507	22.66	6.64	37.8 / 10.0	419	394	295
67,000	19,631	2,970	22.56	6.61	37.8 / 10.0	419	394	295
69,300	20,305	3,085	22.46	6.58	37.8 / 10.0	419	394	295
41,300	12,101	1,800	22.94	6.72	37.8 / 10.0	385	362	263
48,400	14,181	2,170	22.30	6.54	37.8 / 10.0	385	362	263
56,800	16,642	2,496	22.76	6.67	37.8 / 10.0	419	394	295
68,900	20,188	3,025	22.78	6.67	37.8 / 10.0	419	394	295
34,300	10,050	1,488	23.05	6.75	37.8 / 10.0	385	363	263
41,500	12,160	1,800	23.06	6.76	37.8 / 10.0	385	363	263
47,300	13,859	2,030	23.30	6.83	37.8 / 10.0	419	394	295
56,800	16,642	2,480	22.90	6.71	37.8 / 10.0	419	394	295
56,800	16,642	2,485	22.86	6.70	37.8 / 10.0	419	394	295
69,000	20,217	3,020	22.85	6.69	37.8 / 10.0	419	394	295



Specification

2 Stage Modulating R410A

Type	Frequency	Voltage	Series	Model	Power Mode (Full Load)					
					Cooling Capacity		Input	EER	COP	Test Condition (Cond / Eva Temp)
					Btu/hr	Watts	Watts	Btu/W-hr	W/W	°C
LSS	60 Hz	1Φ, 208 - 230 V	APM	APM016KA	20,000	5,861	1,316	15.20	4.45	46.1 / 10.0
				APM020KA	25,100	7,356	1,673	15.00	4.40	46.1 / 10.0
				APM021KA	26,400	7,737	1,703	15.50	4.54	46.1 / 10.0
				APM030KA	37,900	11,107	2,429	15.60	4.57	46.1 / 10.0
				APM031KA	38,000	11,136	2,436	15.60	4.57	46.1 / 10.0
		ABM	ABM035KA	45,000	13,188	2,813	16.00	4.69	46.1 / 10.0	
			ABM040KA	50,900	14,917	3,222	15.80	4.63	46.1 / 10.0	
			ABM042KA	51,500	15,093	3,219	16.00	4.69	46.1 / 10.0	
			ABM051KA	64,100	18,786	4,006	16.00	4.69	46.1 / 10.0	
			ABM040RA	51,000	14,946	3,150	16.19	4.74	46.1 / 10.0	
	3Φ, 208 - 230 V	ABM	ABM042RA	51,700	15,152	3,191	16.20	4.75	46.1 / 10.0	
			ABM051RA	64,100	18,786	3,980	16.11	4.72	46.1 / 10.0	
			ABM040TA	51,000	14,947	3,150	16.19	4.75	46.1 / 10.0	
			ABM051TA	64,100	18,786	3,980	16.11	4.72	46.1 / 10.0	
			ABM040WA	51,000	14,947	3,150	16.19	4.75	46.1 / 10.0	
	3Φ, 460 V	ABM	ABM042WA	51,500	15,093	3,219	16.00	4.69	46.1 / 10.0	
			ABM051WA	64,100	18,786	3,940	16.27	4.77	46.1 / 10.0	
			ABM040WA	41,700	12,221	2,580	16.16	4.74	46.1 / 10.0	
			ABM042WA	42,700	12,514	2,711	15.75	4.62	46.1 / 10.0	
			ABM051WA	52,800	15,474	3,250	16.25	4.76	46.1 / 10.0	
50 Hz	3Φ, 380 - 420 V	ABM	ABM040WA	41,700	12,221	2,580	16.16	4.74	46.1 / 10.0	
ABM042WA	42,700	12,514	2,711	15.75	4.62	46.1 / 10.0				
ABM051WA	52,800	15,474	3,250	16.25	4.76	46.1 / 10.0				

*LSS : Low Side Shell

Saving Mode (Part Load)						Modulation Ratio	Dimension (mm)			Solenoid Valve
Cooling Capacity		Input	EER	COP	Test Condition (Cond / Eva Temp)		Power / Saving	A	B	C
Btu/hr	Watts	Watts	Btu/W-hr	W/W	°C					
15,500	4,542	820	18.90	5.54	37.8 / 10.0	67%	391	368	263	24Vac, 50/60Hz
19,600	5,744	1,010	19.41	5.69	37.8 / 10.0	67%	391	368	263	24Vac, 50/60Hz
20,900	6,125	1,066	19.61	5.75	37.8 / 10.0	67%	391	368	263	24Vac, 50/60Hz
28,100	8,235	1,419	19.80	5.80	37.8 / 10.0	67%	391	368	263	24Vac, 50/60Hz
28,200	8,264	1,439	19.60	5.74	37.8 / 10.0	67%	391	368	263	24Vac, 50/60Hz
34,000	9,964	1,683	20.20	5.92	37.8 / 10.0	67%	425	400	295	24Vac, 50/60Hz
38,600	11,312	1,901	20.31	5.95	37.8 / 10.0	67%	425	400	295	24Vac, 50/60Hz
39,100	11,459	1,926	20.30	5.95	37.8 / 10.0	67%	425	400	295	24Vac, 50/60Hz
48,100	14,096	2,369	20.30	5.95	37.8 / 10.0	67%	425	400	295	24Vac, 50/60Hz
38,300	11,224	1,890	20.26	5.94	37.8 / 10.0	67%	425	400	295	24Vac, 50/60Hz
39,100	11,459	1,926	20.30	5.95	37.8 / 10.0	67%	425	400	295	24Vac, 50/60Hz
48,300	14,155	2,330	20.73	6.08	37.8 / 10.0	67%	425	400	295	24Vac, 50/60Hz
38,600	11,313	1,890	20.42	5.99	37.8 / 10.0	67%	425	400	295	24Vac, 50/60Hz
48,300	14,155	2,330	20.73	6.08	37.8 / 10.0	67%	425	400	295	24Vac, 50/60Hz
38,600	11,313	1,900	20.32	5.95	37.8 / 10.0	67%	425	400	295	24Vac, 50/60Hz
39,100	11,459	1,926	20.30	5.95	37.8 / 10.0	67%	425	400	295	24Vac, 50/60Hz
48,300	14,155	2,340	20.64	6.05	37.8 / 10.0	67%	425	400	295	24Vac, 50/60Hz
31,400	9,202	1,530	20.52	6.01	37.8 / 10.0	67%	425	400	295	24Vac, 50/60Hz
31,800	9,320	1,563	20.35	5.96	37.8 / 10.0	67%	425	400	295	24Vac, 50/60Hz
38,700	11,342	1,879	20.60	6.04	37.8 / 10.0	67%	425	400	295	24Vac, 50/60Hz

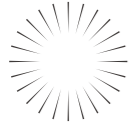

Specification

2 Stage Modulating R454B

Type	Frequency	Voltage	Series	Model	Power Mode (Full Load)						
					Cooling Capacity		Input	EER	COP	Test Condition (Cond / Eva Temp)	
					Btu/hr	Watts	Watts	Btu/W-hr	W/W	°C	
LSS	60 Hz	1φ, 208 - 230 V	YPM	YPM016KA	19,800	5,798	1,245	15.90	4.66	46.1 / 10.0	
				YPM020KA	25,300	7,409	1,543	16.40	4.80	46.1 / 10.0	
				YPM021KA	26,800	7,849	1,634	16.40	4.80	46.1 / 10.0	
				YPM026KA	32,500	9,518	2,006	16.20	4.74	46.1 / 10.0	
				YPM030KA	37,800	11,070	2,305	16.40	4.80	46.1 / 10.0	
				YPM031KA	39,200	11,480	2,382	16.46	4.82	46.1 / 10.0	
		YBM	YBM035KA	45,500	13,325	2,741	16.60	4.86	46.1 / 10.0		
			YBM040KA	50,600	14,819	3,085	16.40	4.80	46.1 / 10.0		
			YBM042KA	52,000	15,229	3,152	16.50	4.83	46.1 / 10.0		
			YBM051KA	63,300	18,538	3,836	16.50	4.83	46.1 / 10.0		
			3φ, 208 - 230 V	YPM	YPM030RA	37,800	11,071	2,291	16.50	4.83	46.1 / 10.0
					YPM031RA	39,100	11,451	2,370	16.50	4.83	46.1 / 10.0
		YPM031TA			39,100	11,451	2,370	16.50	4.83	46.1 / 10.0	
		YBM		YBM035RA	45,500	13,326	2,741	16.60	4.86	46.1 / 10.0	
				YBM040RA	50,600	14,819	3,085	16.40	4.80	46.1 / 10.0	
				YBM042RA	52,000	15,230	3,152	16.50	4.83	46.1 / 10.0	
		3φ, 575 V	YPM	YPM030TA	37,800	11,071	2,291	16.50	4.83	46.1 / 10.0	
				YPM031TA	39,100	11,451	2,370	16.50	4.83	46.1 / 10.0	
	YPM031TA			39,100	11,451	2,370	16.50	4.83	46.1 / 10.0		
	YBM		YBM035TA	45,500	13,326	2,741	16.60	4.86	46.1 / 10.0		
			YBM040TA	50,600	14,819	3,085	16.40	4.80	46.1 / 10.0		
			YBM042TA	52,000	15,230	3,152	16.50	4.83	46.1 / 10.0		
	3φ, 460 V	YPM	YPM030WA	37,800	11,071	2,291	16.50	4.83	46.1 / 10.0		
			YPM031WA	39,100	11,451	2,370	16.50	4.83	46.1 / 10.0		
			YPM031WA	39,100	11,451	2,370	16.50	4.83	46.1 / 10.0		
		YBM	YBM035WA	45,500	13,326	2,725	16.70	4.89	46.1 / 10.0		
			YBM040WA	50,600	14,819	3,085	16.40	4.80	46.1 / 10.0		
			YBM042WA	52,000	15,230	3,152	16.50	4.83	46.1 / 10.0		
	50 Hz	3φ, 380 - 420 V	YPM	YPM030WA	30,500	8,933	1,949	15.65	4.58	46.1 / 10.0	
				YPM031WA	30,200	8,845	1,911	15.80	4.63	46.1 / 10.0	
				YPM031WA	30,200	8,845	1,911	15.80	4.63	46.1 / 10.0	
			YBM	YBM035WA	37,500	10,983	2,246	16.70	4.89	46.1 / 10.0	
				YBM040WA	41,000	12,008	2,634	15.56	4.56	46.1 / 10.0	
				YBM042WA	43,000	12,594	2,590	16.60	4.86	46.1 / 10.0	
	YBM051WA	52,000	15,230	3,114	16.70	4.89	46.1 / 10.0				

*LSS : Low Side Shell

Saving Mode (Part Load)						Modulation Ratio	Dimension (mm)			Solenoid Valve	
Cooling Capacity		Input	EER	COP	Test Condition (Cond / Eva Temp)		Power / Saving	A	B	C	Voltage
Btu/hr	Watts	Watts	Btu/W-hr	W/W	°C						
15,200	4,451	760	20.00	5.86	37.8 / 10.0	67%	391	368	263	24Vac, 50/60Hz	
19,600	5,740	942	20.81	6.09	37.8 / 10.0	67%	391	368	263	24Vac, 50/60Hz	
20,600	6,033	986	20.89	6.12	37.8 / 10.0	67%	391	368	263	24Vac, 50/60Hz	
24,200	7,087	1,152	21.01	6.15	37.8 / 10.0	67%	391	368	263	24Vac, 50/60Hz	
28,100	8,229	1,340	20.97	6.14	37.8 / 10.0	67%	391	368	263	24Vac, 50/60Hz	
29,100	8,522	1,375	21.16	6.20	37.8 / 10.0	67%	391	368	263	24Vac, 50/60Hz	
34,000	9,957	1,619	21.00	6.15	37.8 / 10.0	67%	425	400	295	24Vac, 50/60Hz	
38,300	11,217	1,807	21.20	6.21	37.8 / 10.0	67%	425	400	295	24Vac, 50/60Hz	
39,500	11,568	1,872	21.10	6.18	37.8 / 10.0	67%	425	400	295	24Vac, 50/60Hz	
47,900	14,028	2,259	21.20	6.21	37.8 / 10.0	67%	425	400	295	24Vac, 50/60Hz	
28,100	8,230	1,325	21.21	6.21	37.8 / 10.0	67%	391	368	263	24Vac, 50/60Hz	
29,000	8,493	1,368	21.20	6.21	37.8 / 10.0	67%	391	368	263	24Vac, 50/60Hz	
34,000	9,958	1,604	21.20	6.21	37.8 / 10.0	67%	425	400	295	24Vac, 50/60Hz	
38,300	11,217	1,807	21.20	6.21	37.8 / 10.0	67%	425	400	295	24Vac, 50/60Hz	
39,500	11,568	1,863	21.20	6.21	37.8 / 10.0	67%	425	400	295	24Vac, 50/60Hz	
47,900	14,029	2,238	21.40	6.27	37.8 / 10.0	67%	425	400	295	24Vac, 50/60Hz	
28,100	8,230	1,325	21.21	6.21	37.8 / 10.0	67%	391	368	263	24Vac, 50/60Hz	
29,100	8,523	1,373	21.20	6.21	37.8 / 10.0	67%	391	368	263	24Vac, 50/60Hz	
34,000	9,958	1,604	21.20	6.21	37.8 / 10.0	67%	425	400	295	24Vac, 50/60Hz	
38,300	11,217	1,807	21.20	6.21	37.8 / 10.0	67%	425	400	295	24Vac, 50/60Hz	
39,500	11,568	1,863	21.20	6.21	37.8 / 10.0	67%	425	400	295	24Vac, 50/60Hz	
47,900	14,029	2,238	21.40	6.27	37.8 / 10.0	67%	425	400	295	24Vac, 50/60Hz	
28,100	8,230	1,325	21.21	6.21	37.8 / 10.0	67%	391	368	263	24Vac, 50/60Hz	
29,100	8,523	1,373	21.20	6.21	37.8 / 10.0	67%	391	368	263	24Vac, 50/60Hz	
34,000	9,958	1,596	21.30	6.24	37.8 / 10.0	67%	425	400	295	24Vac, 50/60Hz	
38,300	11,217	1,807	21.20	6.21	37.8 / 10.0	67%	425	400	295	24Vac, 50/60Hz	
39,500	11,568	1,863	21.20	6.21	37.8 / 10.0	67%	425	400	295	24Vac, 50/60Hz	
47,900	14,029	2,238	21.40	6.27	37.8 / 10.0	67%	425	400	295	24Vac, 50/60Hz	
22,000	6,443	1,094	20.11	5.89	37.8 / 10.0	67%	391	368	263	24Vac, 50/60Hz	
23,000	6,736	1,095	21.00	6.15	37.8 / 10.0	67%	391	368	263	24Vac, 50/60Hz	
28,300	8,288	1,322	21.40	6.27	37.8 / 10.0	67%	425	400	295	24Vac, 50/60Hz	
31,400	9,196	1,477	21.26	6.23	37.8 / 10.0	67%	425	400	295	24Vac, 50/60Hz	
32,000	9,372	1,502	21.30	6.24	37.8 / 10.0	67%	425	400	295	24Vac, 50/60Hz	
38,700	11,334	1,792	21.60	6.33	37.8 / 10.0	67%	425	400	295	24Vac, 50/60Hz	



Specification

Variable Speed R410A+R32

Refrigerant	Type	Series	Model	Power	Cooling Capacity		Input	EER	COP	Test Condition	
					Btu/hr	Watts	Watts	Btu/W-hr	W/W	°C	
R410A	LSS	APA	APA026DA	DC380V	25,000	7,322	2,475	10.10	2.96	54.4 / 7.2	
		ABA	ABA042DB	DC380V	44,200	12,945	4,055	10.90	3.19	54.4 / 7.2	
			ABA051DA	DC380V	53,500	15,669	4,864	11.00	3.22	54.4 / 7.2	
	HSS	JQC	JQC048MA	DC540V							
			JQC048MB	DC310V							
			JQC068MA	DC540V							
			JQC068MB	DC310V							
		JBA	JBA096MA	DC540V							
	R1 Compressor™	RJ	RJB036MAB	DC520V	37,100	10,866	3,198	11.60	3.40	54.4 / 7.2	
			RJB036MBA	DC380V	37,100	10,866	3,198	11.60	3.40	54.4 / 7.2	
			RJB036MAA	DC520V	37,100	10,866	3,226	11.50	3.37	54.4 / 7.2	
			RJB036MAB	DC520V	37,100	10,866	3,198	11.60	3.40	54.4 / 7.2	
			RJA040MAB	DC380V	60,700	17,778	3,794	16.00	4.69	46.1 / 10.0	
			RJA020MAB	DC380V	20,700	6,063	1,294	16.00	4.69	46.1 / 10.0	
R32	R1 Compressor™	RJ	RJB036MAA	DC520V	37,700	11,042	3,397	11.10	3.25	54.4 / 7.2	
			RJB036MBA	DC380V	37,650	11,027	3,356	11.22	3.29	54.4 / 7.2	
			RJB036MAB	DC520V	37,650	11,027	3,356	11.22	3.29	54.4 / 7.2	
	HSS	JQC	JQC068MA	DC540V							
			JQC068MB	DC310V							

*LSS : Low Side Shell
*HSS : High Side Shell

Cooling Capacity		Input	EER	COP	Test Condition	Range	Dimension (mm)		
Btu/hr	Watts	Watts	Btu/W-hr	W/W	°C	rps	A	B	C
31,000	9,079	1,566	19.80	5.80	37.8 / 7.2	20-70	407	379	250
53,500	15,669	2,716	19.70	5.77	37.8 / 7.2	20-70	449	416	297
64,500	18,890	3,241	19.90	5.83	37.8 / 7.2	20-70	449	416	297
61,000	17,877	2,905	21.00	6.15	37.8 / 7.2	12-165	489	426	337
61,500	18,024	2,943	20.90	6.12	37.8 / 7.2	12-165	489	426	337
85,000	24,911	4,060	20.94	6.14	37.8 / 7.2	12-165	489	426	337
85,000	24,911	4,130	20.58	6.03	37.8 / 7.2	12-165	489	426	337
121,500	35,608	5,690	21.35	6.26	37.8 / 7.2	12-160	527	458	379
37,000	10,836	1,697	21.80	6.39	37.8 / 7.2	10-150	366	356	322
37,000	10,836	1,697	21.80	6.39	37.8 / 7.2	10-150	366	356	322
37,000	10,836	1,721	21.50	6.30	37.8 / 7.2	10-150	366	356	322
37,000	10,836	1,697	21.80	6.39	37.8 / 7.2	10-150	366	356	322
30,700	8,992	1,323	23.20	6.80	37.8 / 10.0	15-120	366	356	322
13,200	3,866	595	22.18	6.50	37.8 / 10.0	15-120	366	356	322
36,600	10,719	1,803	20.30	5.95	37.8 / 7.2	10-150	366	356	322
36,350	10,647	1,766	20.58	6.03	37.8 / 7.2	10-150	366	356	322
36,350	10,647	1,766	20.58	6.03	37.8 / 7.2	10-150	366	356	322
89,000	26,079	4,258	20.90	6.12	37.8 / 7.2	12-165	489	426	337
89,600	26,225	4,400	20.36	5.96	37.8 / 7.2	12-165	489	426	337



Specification

For Refrigeration Application

Type	Frequency	Voltage	Series	Model	Cooling Capacity		Input	EER	COP	Test Condition (Cond / Eva Temp)	
					Btu/hr	Watts	Watts	Btu/W-hr	W/W	°C	
LSS	60 Hz	1φ, 208 - 230 V	MPA	MPA010KA	15,300	4,481	1,779	8.60	2.52	54.4 / 7.2	
				MPA013KA	19,800	5,799	2,176	9.10	2.66	54.4 / 7.2	
				MPA015KA	23,400	6,853	2,543	9.20	2.69	54.4 / 7.2	
				MPA019KA	26,100	7,644	2,868	9.10	2.67	54.4 / 7.2	
			MBA	MBA021KA	34,400	10,075	3,909	8.80	2.58	54.4 / 7.2	
				MBA026KA	38,500	11,276	4,278	9.00	2.64	54.4 / 7.2	
				MBA029KA	43,000	12,594	4,725	9.10	2.67	54.4 / 7.2	
				MBA033KA	48,100	14,087	5,286	9.10	2.66	54.4 / 7.2	
			MRA	MRA038KA	54,000	15,815	6,585	8.20	2.40	54.4 / 7.2	
			3φ, 208 - 230 V	MPA	MPA010RA	15,400	4,510	1,770	8.70	2.55	54.4 / 7.2
					MPA013RA	19,600	5,740	2,227	8.80	2.58	54.4 / 7.2
					MPA015RA	23,000	6,736	2,566	8.96	2.63	54.4 / 7.2
		MPA019RA			25,800	7,556	2,867	9.00	2.64	54.4 / 7.2	
		MBA		MBA021RA	34,500	10,104	3,833	9.00	2.64	54.4 / 7.2	
				MBA026RA	38,100	11,159	4,187	9.10	2.67	54.4 / 7.2	
				MBA029RA	43,000	12,594	4,674	9.20	2.69	54.4 / 7.2	
				MBA033RA	48,100	14,087	5,344	9.00	2.64	54.4 / 7.2	
		MRA		MRA038RA	54,500	15,962	6,337	8.60	2.52	54.4 / 7.2	
		MRA045RA		65,000	19,037	7,558	8.60	2.52	54.4 / 7.2		
		3φ, 380 V		MPA	MPA015UA	22,600	6,619	2,511	9.00	2.64	54.4 / 7.2
				MBA	MBA021UA	34,500	10,104	3,833	9.00	2.64	54.4 / 7.2
			MBA029UA		43,000	12,594	4,674	9.20	2.69	54.4 / 7.2	
			MBA033UA		48,400	14,175	5,261	9.20	2.69	54.4 / 7.2	
		3φ, 460 V	MPA	MPA010SA	15,500	4,540	1,761	8.80	2.58	54.4 / 7.2	
				MPA013SA	19,600	5,740	2,202	8.90	2.61	54.4 / 7.2	
				MPA015SA	22,800	6,678	2,533	9.00	2.64	54.4 / 7.2	
				MPA019SA	25,600	7,498	2,844	9.00	2.64	54.4 / 7.2	
			MBA	MBA021SA	34,600	10,133	3,844	9.00	2.64	54.4 / 7.2	
				MBA026SA	38,000	11,129	4,176	9.10	2.66	54.4 / 7.2	
				MBA029SA	42,800	12,535	4,652	9.20	2.69	54.4 / 7.2	
				MBA033SA	48,100	14,087	5,286	9.10	2.66	54.4 / 7.2	
			MRA	MRA038SA	54,700	16,020	6,360	8.60	2.52	54.4 / 7.2	
			MRA045SA	65,000	19,037	7,558	8.60	2.52	54.4 / 7.2		

*LSS : Low Side Shell

For Heatpump Application

Type	Type	Frequency	Voltage	Series	Model	Cooling Capacity		Input		EER	COP	EER	COP	Test Condition (Cond / Eva Temp)
						Btu/hr	Watts	Watts	Btu/W-hr	W/W	Btu/W-hr	W/W	°C	
R410A	R1 Compressor™	10 ~ 150 Hz	DC520V	RJ	RJB036MAC	35,000	10,251	3,125	11.2	3.41	11.20	3.28	54.4 / 7.2	

Cooling Capacity		Input	EER	COP	Test Condition (Cond / Eva Temp)	Dimension (mm)		
Btu/hr	Watts	Watts	Btu/W-hr	W/W	°C	A	B	C
9,700	2,841	1,540	6.30	1.84	48.9 / -6.7	387	359	230
12,500	3,661	1,894	6.60	1.93	48.9 / -6.7	387	359	230
15,200	4,452	2,171	7.00	2.05	48.9 / -6.7	387	359	230
16,900	4,950	2,449	6.90	2.02	48.9 / -6.7	387	359	230
22,400	6,560	3,294	6.80	1.99	48.9 / -6.7	418	385	266
25,000	7,322	3,623	6.90	2.02	48.9 / -6.7	418	385	266
27,700	8,113	4,014	6.90	2.02	48.9 / -6.7	418	385	266
31,100	9,108	4,574	6.80	1.99	48.9 / -6.7	418	385	266
37,000	10,836	5,522	6.70	1.96	48.9 / -6.7	455	422	304
9,600	2,812	1,548	6.20	1.82	48.9 / -6.7	387	359	230
12,700	3,720	1,954	6.50	1.90	48.9 / -6.7	387	359	230
14,900	4,364	2,191	6.80	1.99	48.9 / -6.7	387	359	230
16,800	4,920	2,507	6.70	1.96	48.9 / -6.7	387	359	230
22,400	6,560	3,294	6.80	1.99	48.9 / -6.7	418	385	266
24,800	7,263	3,594	6.90	2.02	48.9 / -6.7	418	385	266
27,800	8,142	3,971	7.00	2.05	48.9 / -6.7	418	385	266
31,300	9,167	4,536	6.90	2.02	48.9 / -6.7	418	385	266
37,200	10,895	5,314	7.00	2.05	48.9 / -6.7	455	422	304
45,100	13,209	6,264	7.20	2.11	48.9 / -6.7	455	422	304
14,750	4,320	2,169	6.80	1.99	48.9 / -6.7	387	359	230
22,300	6,531	3,279	6.80	1.99	48.9 / -6.7	418	385	266
27,800	8,142	3,971	7.00	2.05	48.9 / -6.7	418	385	266
31,500	9,226	4,437	7.10	2.08	48.9 / -6.7	418	385	266
9,650	2,826	1,556	6.20	1.82	48.9 / -6.7	387	359	230
12,700	3,720	1,924	6.60	1.93	48.9 / -6.7	387	359	230
14,900	4,364	2,191	6.80	1.99	48.9 / -6.7	387	359	230
16,800	4,920	2,471	6.80	1.99	48.9 / -6.7	387	359	230
22,400	6,560	3,294	6.80	1.99	48.9 / -6.7	418	385	266
24,800	7,263	3,594	6.90	2.02	48.9 / -6.7	418	385	266
27,700	8,113	4,014	6.90	2.02	48.9 / -6.7	418	385	266
31,300	9,167	4,536	6.90	2.02	48.9 / -6.7	418	385	266
37,800	11,071	5,324	7.10	2.08	48.9 / -6.7	455	422	304
45,200	13,238	6,278	7.20	2.11	48.9 / -6.7	455	422	304

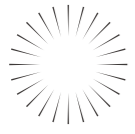

Drawing

[Dimension : mm]

· ABT

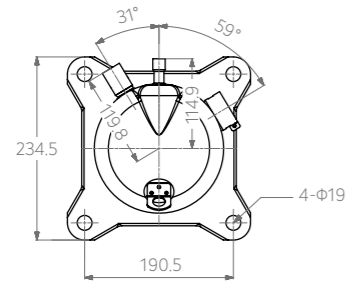

· APA

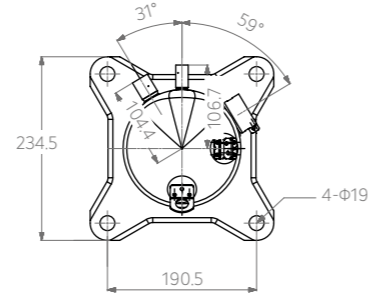

· ABA

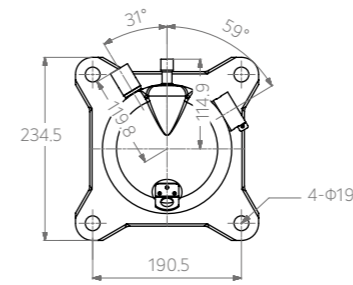

· ARA

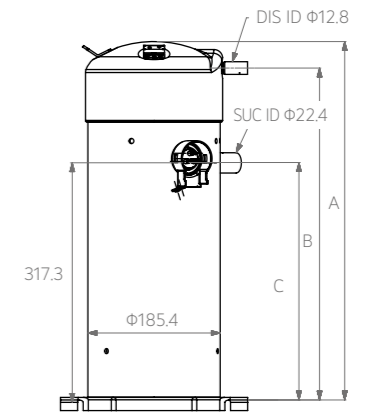
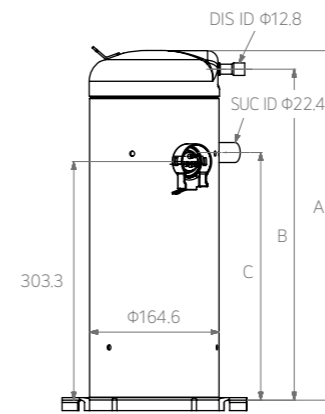
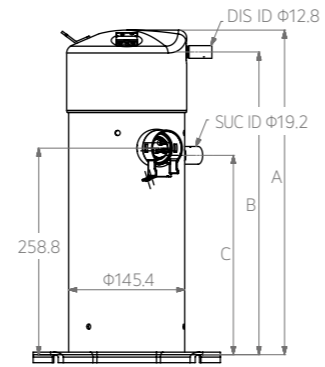
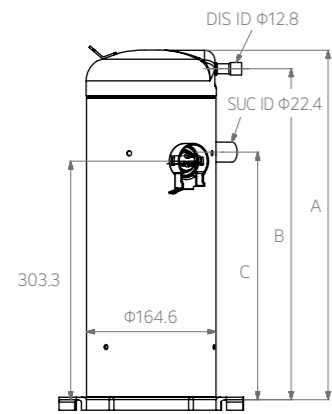
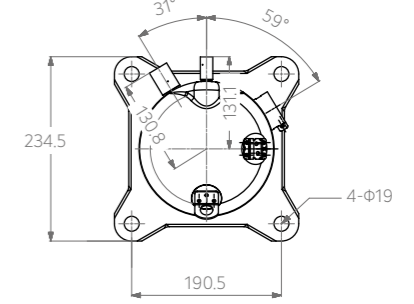

· APG

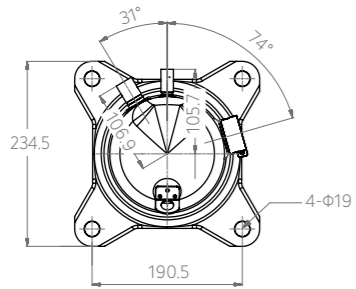

· APH / YPH

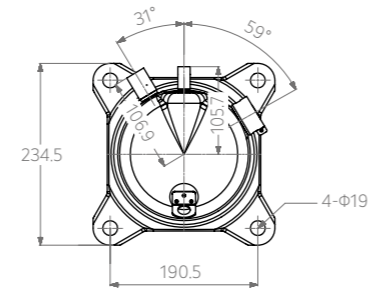

· ABG / ABH / YBH

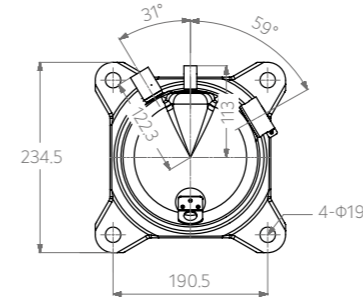

· RJ

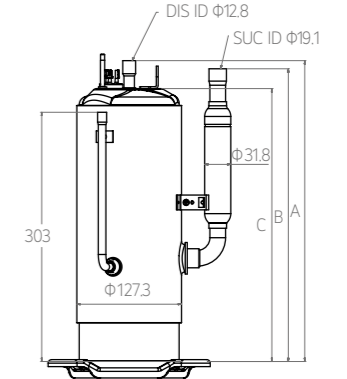
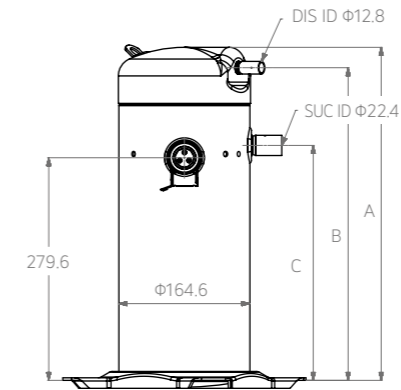
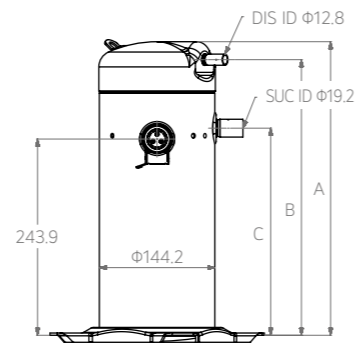
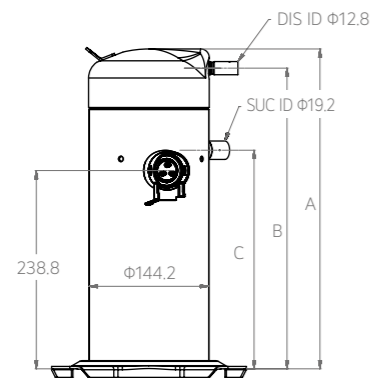
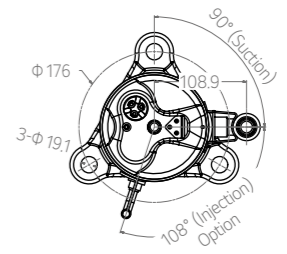



Drawing

[Dimension : mm]

· APM / YPM

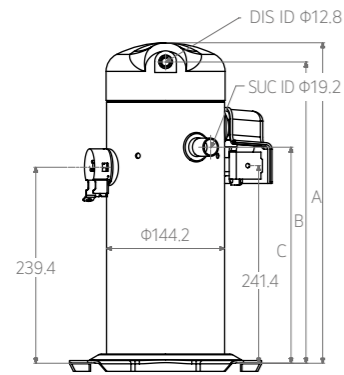
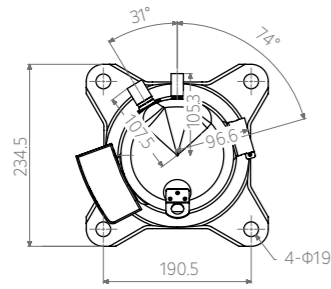

· ABM / YBM

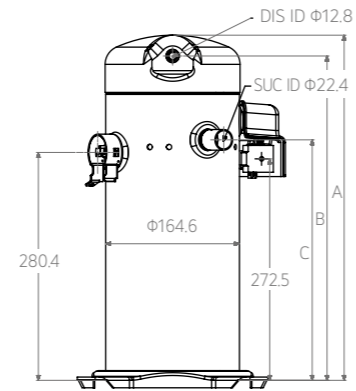
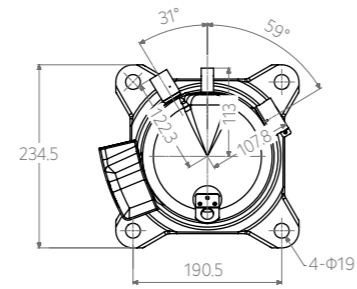

· JQC

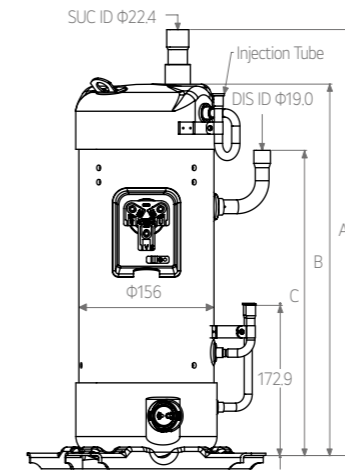
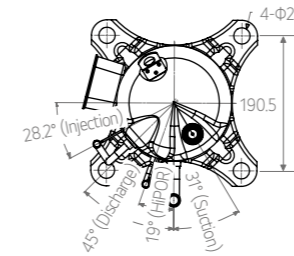

· JBA

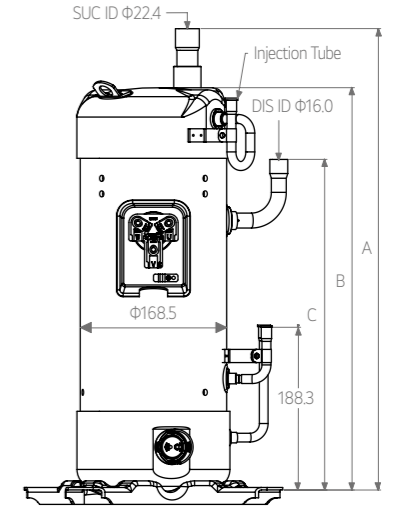
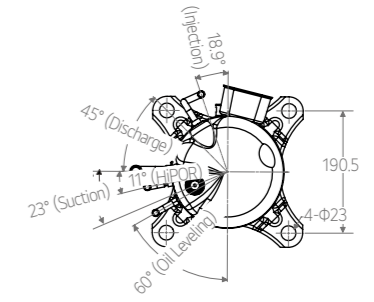

· MPA

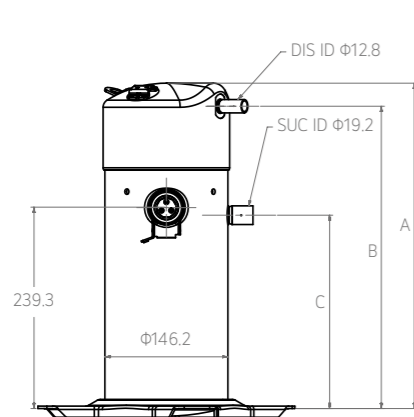
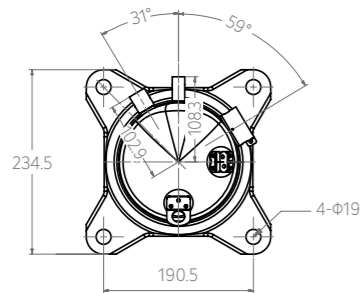

· MBA

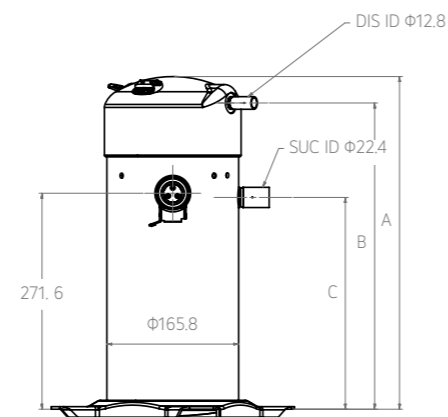
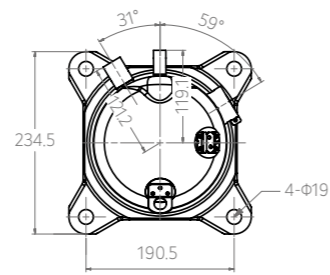

· MRA

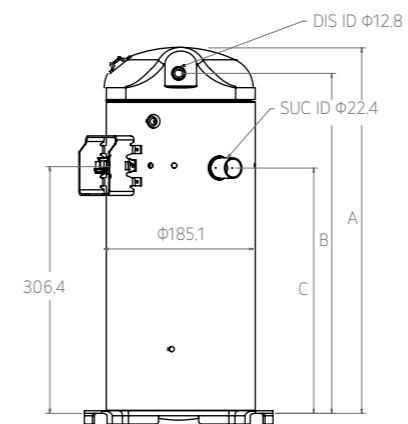
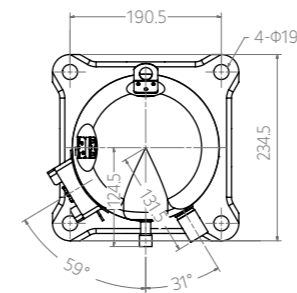



Specification

Residential Inverter Drive

Contents		Spec	1 kW	4 kW	6 kW	7 kW
Drive	1	Model Name	A*01K001	A*04K001	A*06K001	A*07K001
	2	Rated Input Voltage [V]	1Φ 208 - 230			
	3	Input Frequency [Hz]	50-60			
	4	Maximum Input Current [Arms]	5.5	18	27	31
	5	Maximum Input Power [W]	1,000	4,000	6,000	7,000
	6	Operating Compressor Speed [Hz]	15 ~ 90		10 ~ 120	
	7	Converter Type	HPSC	PFC		
	8	Compressor Connection Color	-	Red (U) / Blue (V) / Yellow (W)		
	9	Ambient Operating Temperature [°C]	0 ~ 40		-20 ~ 48	
	10	Storage Temperature [°C]	-40 ~ 60			
	11	Max. Storage Relative Humidity [%]	85			
Reactor	1	Model Name	PDR010L011	PDR040K350	PDR060K350	
	2	Rated Input Voltage [V]	1Φ 208 - 230			
	3	Input Frequency [Hz]	50 - 60			
	4	Maximum input current	6 A	20 A	25 A	
	5	Inductance at 30 kHz, 1 V (25°C)	13 mH ±10%	220 uH ±15%	200 uH ±15%	

· A*01K001

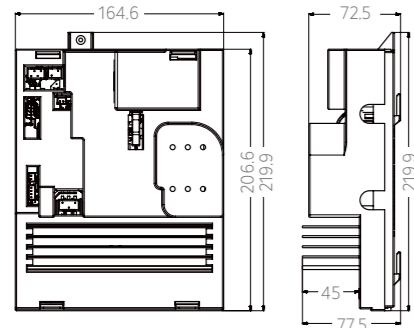

· A*04K001

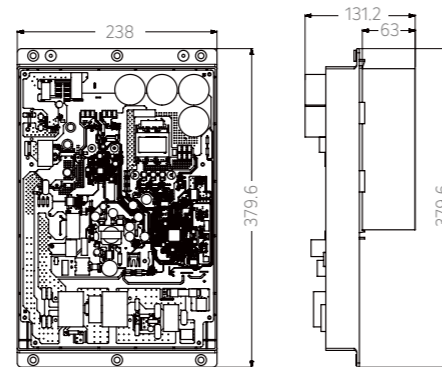

· A*06K001

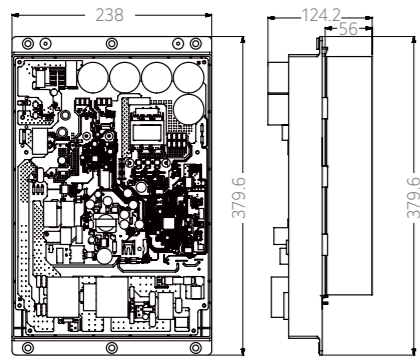

Commercial Inverter Drive

Contents		Spec	7 kW		
Drive	1	Model Name	A*07R101A	A*07S101A	A*07T101A
	2	Rated Input Voltage [V]	3Φ 208 - 230	3Φ 460	3Φ 575
	3	Input Frequency [Hz]	60		
	4	Maximum Input Current [Arms]	21	11	9
	5	Maximum Input Power [W]	7,000		
	6	Operating Compressor Speed [Hz]	15 ~ 150		
	7	Converter Type	Bridge Diode		
	8	Compressor Connection Color	Red (U) / Blue (V) / Yellow (W)		
	9	Ambient Operating Temperature [°C]	-20 ~ 48	-20 ~ 48	-20 ~ 52
	10	Storage Temperature [°C]	-40 ~ 60		
	11	Max. Storage Relative Humidity [%]	85	85	95
Noise Filter	1	Current Range [Peak Current]	50		
	2	Rated Frequency [Hz]	50 / 60		
	3	Leakage Current	6.0 mA MAX. at AC 380 V 50/60 Hz (R,S,T - Gnd)		
	4	Insulation Resistance	Line to Gnd, AC 1500 V for 1 Min. (AC 1800 V for 1Sec.)		
	5	Operating Temperature [°C]	-40 ~ 85		
	6	Storage Temperature [°C]	-40 ~ 90		
Transformer	1	Model Name	PDR070R040	PDR070S030	PDR070T040
	2	Rated Input Voltage [V]	230	460	575
	3	Rated Input Frequency [Hz]	50 / 60	50 / 60	50 / 60
	4	Rated Output Voltage [V]	230	230	230

· A*07R101A

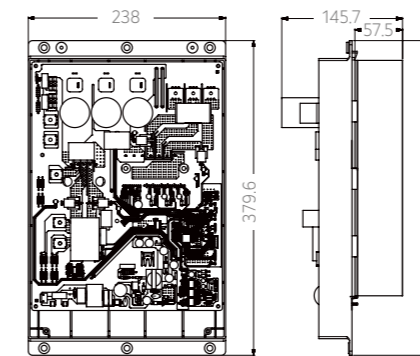

· A*07S101A

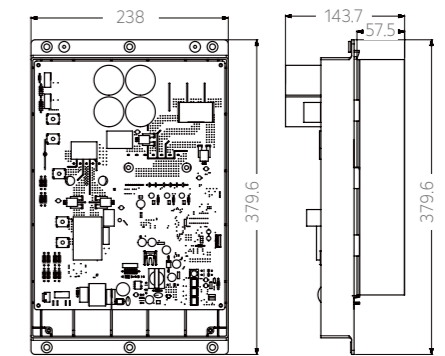

· A*07T101A

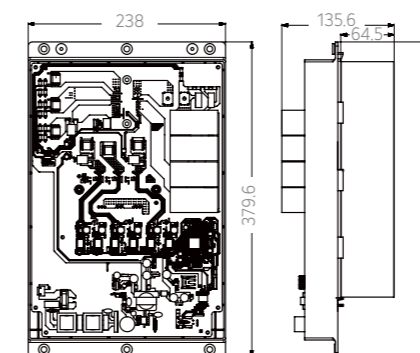



Wiring Diagram

1 HP

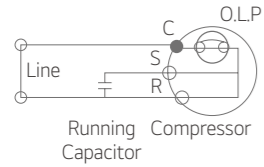

*O.L.P : Over Load Protector

Cover Terminal Fitting

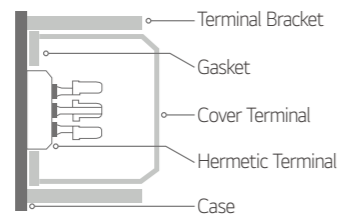

3 HP

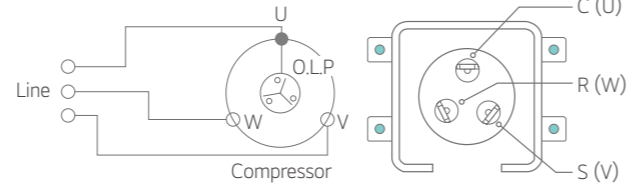

*C.S.R mark is embossed on a Cover terminal.



Mounting

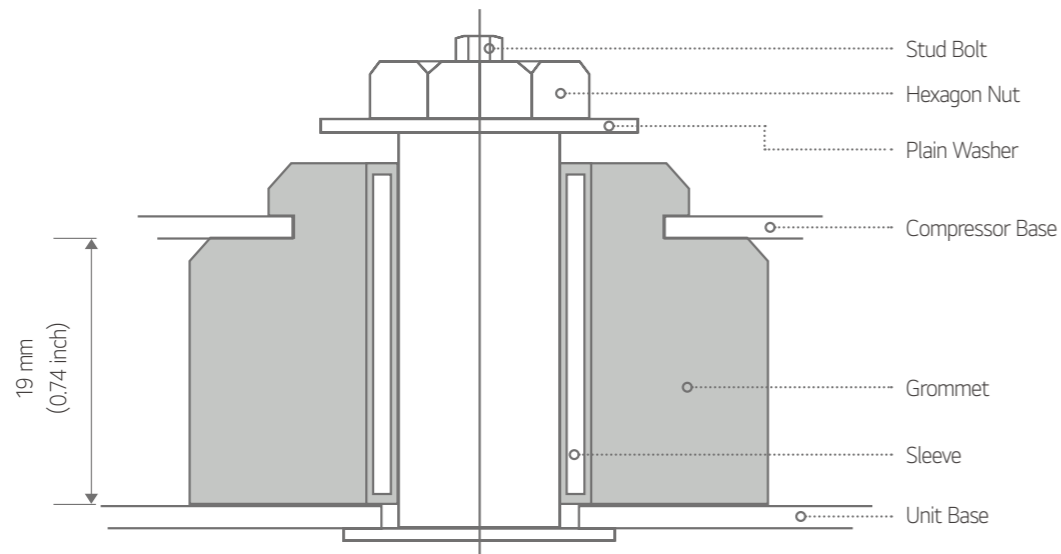

Accessory Parts



Note : 4 kW Drive has on board noise filter.

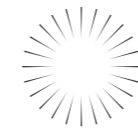

Packing & Container Stuffing Quantity

Items	1 Step pallet		2 Steps pallet		1 Container (20 ft)				
	Packing quantity	Size B	Packing quantity	Size B	Packing quantity	Pallet quantity			
Series						Step 1	Step 2	Accessory	Total
APG / APH / YPH / APM / YPM	12	560	24	980 ↓	576	0	24	0	24
ABG / ABH / YBH / ABM / YBM	16	560	32	980 ↓	640	0	20	0	20
ARA	12	-	24	985 ↓	408	14	10	1	25
JB / JQ	9	-	18	985 ↓	315	35	-	1	36

Note 1 : Only available 1 Step pallet for HSS.

Note 2 : Packing conditions are subjects to change without notice.

Packing Quantity 12, 9

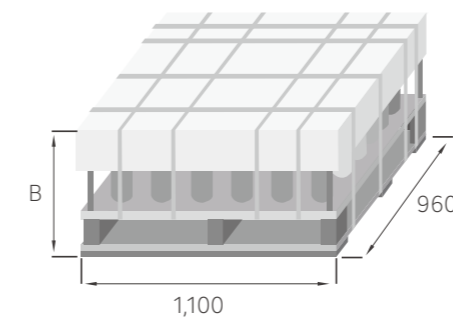

Packing Quantity 16

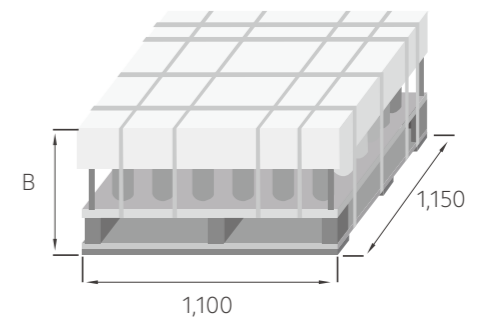

[Unit : mm]

